

EC DECLARATION OF CONFORMITY

Date of issue: 1 September 2018

Reference batch number:
(to be entered by the customer)

Directive:

Machinery Directive 2006/42/EC as amended by Directive 2009/127/EC

Conforming apparatus:

Product: Halfords 2 Tonne Hydraulic Trolley Jack

Model: TH22005

Item code: 657081

Manufacturer:

Halfords Limited, Icknield street Drive, Redditch, Worcestershire, B98 0DE

Harmonised standards referenced or applied:

EN1494:2000 + A1:2008 Mobile or movable jacks and associated lifting equipment

The Supply of Machinery (Safety) Regulations 2008 Statutory instrument 2008 No.1597

The Supply of Machinery (Safety) (Amendment) Regulations 2011 Statutory instrument 2011 No.2157

Halfords Limited hereby declare that the machine described below is both in its basic design and construction and in the version marketed by us conforms to the relevant safety and health related requirements of the appropriate EC Directives. This declaration shall cease to be valid if modifications are made to the machine without our approval.

Date of placement onto market: September 2018

Signed.....

CHRIS HALL
Head of Quality
1 September 2018

CONTACT US

Halfords Ltd, B98 0DE.
www.halfords.com
Produced for Halfords

halfords

INSTRUCTION MANUAL

2 TONNE HYDRAULIC TROLLEY JACK

SWL (SAFE WORKING LOAD) UP TO 2 TONNE (2,000KG)

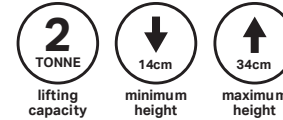

Item Code: 657081
Model: TH22005



INTRODUCTION

For your safety please read this manual before using any lifting equipment ensuring you fully understand its operation and the safety procedures to be observed. Ensure this manual is retained for future reference and that new users of this product read and understand the content before they use the product.

GUARANTEE

This product is guaranteed by Halfords against manufacturing defects for a period of 12 months from the date of purchase. This does not affect your statutory rights. Should you experience a problem please return the product, together with the receipt and this manual to your nearest Halfords store.

WARNING

Failure to comply with these instructions can cause serious injury and damage to the vehicle. If you are in any way unsure, do not attempt to use this product and consult a qualified mechanic.

1. Read and understand instruction manuals fully before use. Use only as specified.
2. Never overload this jack by exceeding its rated safe working load.
3. Check vehicle owner's manual for gross vehicle weight.
4. This jack is for lifting purposes only.
5. Ensure all body parts are kept clear of the jack and vehicle during the raising and lowering operation.
6. After lifting the vehicle, support immediately with properly rated axle stands.
7. Never work on or under a vehicle without using properly rated axle stands.
8. Only use on solid, even and level ground with the wheels chocked, the vehicle in gear and its hand brake on.
9. Ensure that the wheels of the jack are rolling freely, all 4 wheels of the jack remain on the ground during operation.
10. Always ensure that the load is centred on the jack saddle. Off centre loads can become unstable and slip resulting in possible damage or injury.
11. Only use jacking points specified by your vehicle manufacturer. Some vehicles may require a manufacturer specific adaptor. Check vehicle handbook for location and details.
12. Ensure vehicle jacking points are in good, sound condition with no corrosion etc.
13. Do not attempt to move or dolly the vehicle whilst on the jack.
14. This jack is not designed to support extensions, cradles etc.
15. Do not attempt to modify this jack in any way.
16. Do not attempt to use this jack if you suspect a fault.
17. Do not start the vehicle in its raised position.
18. Do not attempt to enter the vehicle and ensure all passengers are out of the vehicle when using this product.

PARTS OF THE JACK

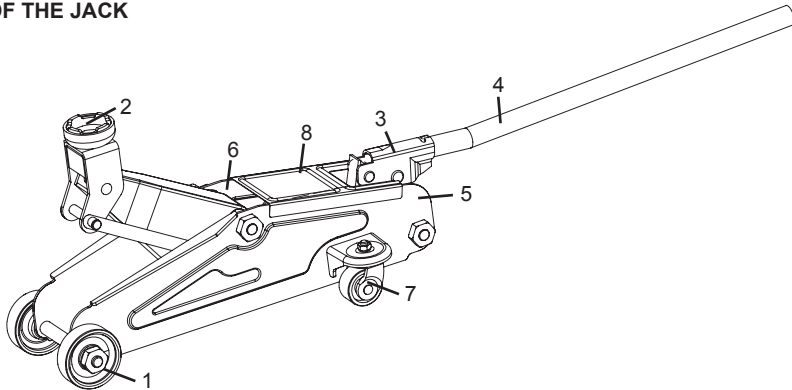

1. Front castor
2. Saddle
3. Handle fork
4. Handle
5. Release valve
6. Handle storage hook
7. Rear castor assembly
8. Top cover plate

FOR YOUR SAFETY AND TO PREVENT INJURY:



Use Service Jack For
Lifting purposes
ONLY.



Always support
Vehicle with
Jack stands.

BEFORE FIRST USE

Air may become trapped in the hydraulic system during transit. To purge air:

1. Open the release valve by rotating the handle counter clockwise one full turn.
2. Place the handle in the handle socket and pump about 4 full strokes to purge the air from the pump and valving.
3. Close the release valve. Pump the handle until the jack has reached full extension. Continue to pump several times to purge air from under the ram.
4. Open the release valve and push ram into its lowest position. Close the release valve and operate normally.

Note: If the jack responds immediately to pump action, it is free of air and ready for operation. If not, repeat procedure.

INSPECTION BEFORE EACH USE

Visual inspection should be made before each use of the jack. Check for leaking hydraulic fluid, cracked welds and damaged, loose or missing parts. Any jack which appears to be damaged in any way, found to be badly worn, operates abnormally, or has been subjected to an abnormal load or shock **MUST NOT BE USED**.

OPERATING INSTRUCTIONS

IMPORTANT: Only use jacking points specified by your vehicle manufacturer. Some vehicles may require a manufacturer specific adaptor. Check vehicle handbook for location and details.

TO MOVE:

Place handle in operating lever. Do not move the jack when handle is on the release valve as this may cause damage to the jack. Do not attempt to move the jack whilst under load.

TO LIFT THE VEHICLE:

1. Park the vehicle on solid, even and level ground. Apply the hand brake, place the vehicle in gear (P if automatic) and chock the wheels that will remain on the ground.
2. Using the jack handle as a wrench, turn the release valve clockwise until fully tightened, **DO NOT OVERTIGHTEN**.
3. Place the handle into the operating lever and position the jack under the jacking point of the vehicle. Pump up and down until the saddle reaches the jacking point. Before lifting, **ALWAYS** ensure that the load point is centred on the jack saddle and cannot slip. Off centre loads can become unstable and slip resulting in damage or injury.
4. Once secure on the jacking point, begin to raise load to desired height by pumping the handle. **IMMEDIATELY** support the vehicle by placing properly rated axle stands under a strong, stable point on the vehicle. Consult the vehicle owner's manual and axle stand instruction manual for guidance. **DO NOT CRAWL UNDER VEHICLE WHILE LIFTING VEHICLE OR PLACING OR REMOVING JACK STANDS!**

- Once the axle stands are properly located, VERY SLOWLY turn the release valve anti-clockwise until the vehicle begins to lower onto the stands. Lower the vehicle slowly so as not to shock load the jack stands.
- BEFORE GOING UNDER THE VEHICLE ensure that all axle stands and chocks are correctly in place and there is no chance of the vehicle becoming unstable.

TO LOWER THE VEHICLE:

Once repairs are completed raise the vehicle slightly, remove the axle stands and using the handle as a wrench, VERY SLOWLY turn the release valve anti-clockwise until the vehicle begins to lower.

CAUTION: Ensure all body parts are kept clear of the jack and vehicle during the raising and lowering operation.

MAINTENANCE, CARE AND LUBRICATION

- This jack contains no user serviceable parts. Any modification will render the jack unsafe.
- All moving joints require lubricating often. Lubricate all linkages, pivot points and castor wheels using a grease gun.
- Regularly check the plunger, main piston and linkages for signs of corrosion. Clean any light surface corrosion with a suitable maintenance spray. If the corrosion is deeper than surface do not attempt to use.
- When not in use Keep the jack stored on all 4 wheels with the arm and plunger all the way down to prevent corrosion.

TO ADD OIL

IMPORTANT When adding or replacing oil, ONLY use a quality hydraulic oil adhering to ISO VG 32 or similar. DO NOT use brake fluid, transmission fluid, alcohol, glycerine, detergent motor oil, or dirty oil etc. as improper fluid will cause serious internal damage to jack making it unsafe to use.

- Place the jack on level ground with the lifting arm and plunger fully lowered.
- Remove the top cover plate and clean the surrounding area of the oil filler plug and remove ensuring that no dirt etc falls into the unit (see Fig.1).
- Oil should be filled to level indicated in the diagram. If low, add hydraulic oil as required.

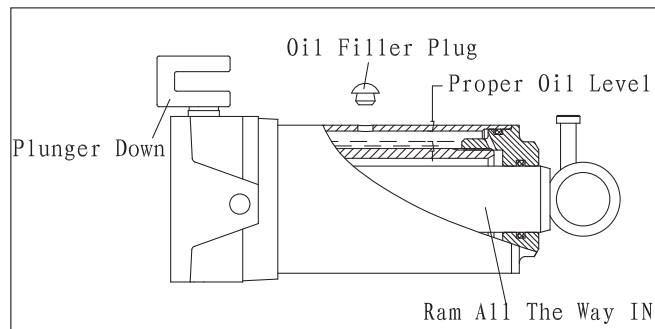
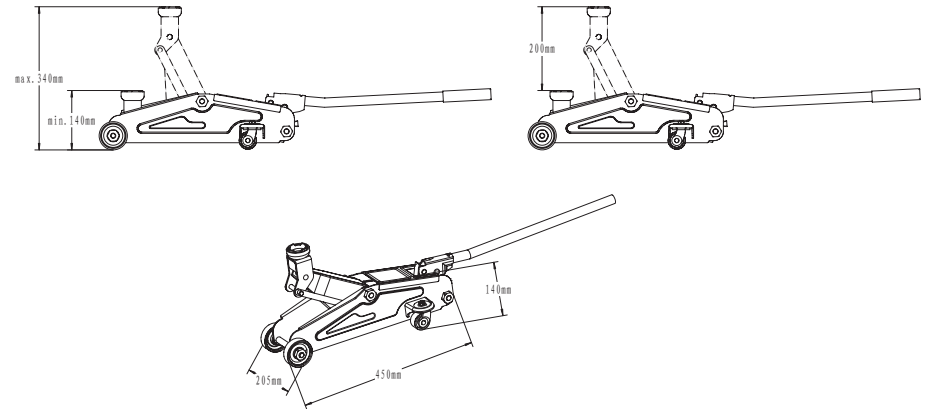

Fig.1

Maintenance and inspection: The owner and/ or user must maintain and inspect the jack in accordance with the manufacturer's instructions.

Jack handle raised or lowered under load	Jack will not lift load	Jack will not hold load	Jack will not lift to full height	Jack will not lift smoothly	Jack will not lower completely	Trouble Shooting Check List
●	●				●	Internal valves are not fully seated: (I) Lower the ram, close the release valve and remove oil filler plug. (II) Pull up the arm by hand to its full height. (III) Open the release valve, close the ram and replace oil filler plug.
	●		●	●	●	The jack could be air locked: (I) Open the release valve and remove oil filler plug. (II) Pump handle for 6 full strokes and close the release valve. Re-fit the oil filler plug.
			●	●		The jack could be over filled with oil: See maintenance instructions for correct procedure.
	●		●	●		The jack oil level may be low: Remove the oil filler plug and refill with hydraulic jack oil to the correct level when the ram is fully down, see maintenance instructions - DO NOT USE BRAKE FLUID.
	●	●				The release valve is not tightly closed: Close release valve by tuning it fully clockwise.
					●	Unit needs lubrication - oil external moving parts, see maintenance instructions.

SPECIFICATIONS



- Low height.....14cm
- High height.....34cm
- Saddle diameter..... 6.7cm
- Handle length.....42cm
- Base length..... 45cm
- Chassis width..... 20.5cm

All dimensions are approximate.