

TIGERFLEX® SHIPLAP APEX BIKE SHED

GENERAL ASSEMBLY INSTRUCTIONS

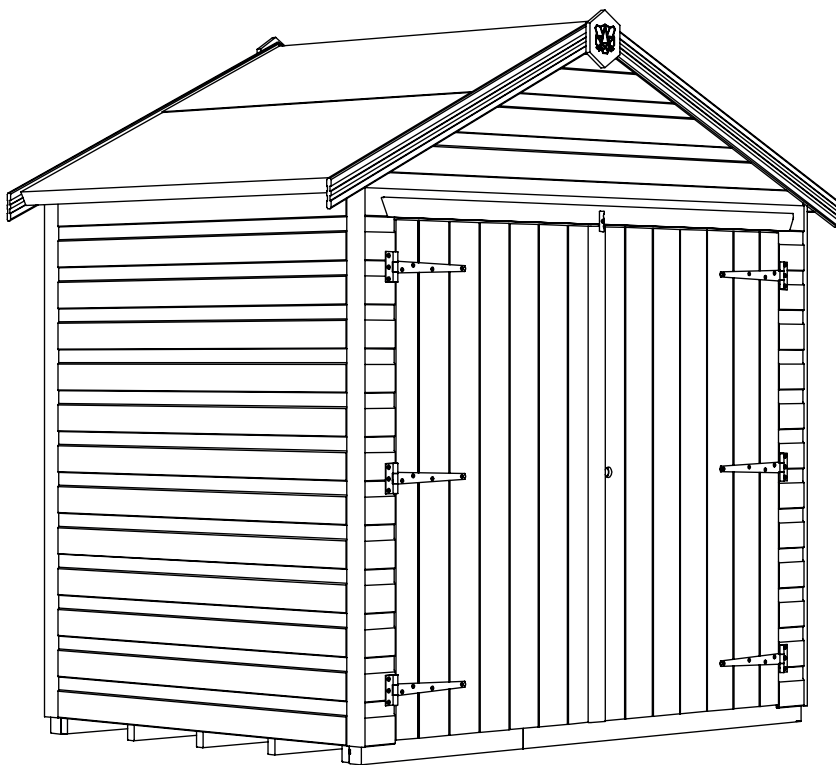

BEFORE YOU GET STARTED

PLEASE READ INSTRUCTIONS CAREFULLY

- Check the pack and make sure you have all the parts listed.
- When you are ready to start, make sure you have the right tools at hand (not supplied).
- Ensure there is plenty of space and a clean, dry area for assembly.

TIMBER

As with all natural materials, timber can be affected during various weather conditions. For the duration of heavy or extended periods of rain, swelling of the wood panels may occur. Warping, cupping or contraction of the wood may also occur during excessive dry spells due to an interior moisture loss. Unfortunately, these processes cannot be avoided but can be mitigated. It is suggested that the outdoor building is sprayed with water during extended periods of warm sunshine and sheltered as much as possible during rain or snow.



SUMMER
CONTRACTION



WINTER
EXPANSION



WOOD WARPING
MAY OCCUR

To validate your guarantee and ensure longevity of the product, it is ESSENTIAL that your building is treated with a suitable wood preserver or paint AFTER assembly, both internally and externally.

BUILDING A BASE

Care must be taken to ensure the product is placed on a suitable base. When thinking about where the building and base is going to be constructed: Ensure that there will be access to all sides for maintenance work and annual treatment.

Ensure the base is level and is built on firm ground, to prevent distortion. Refer to diagrams for the base dimensions which can be found on the product page at [tigersheds.com](https://www.tigersheds.com), it is recommended that the base should be slightly smaller than the external measurement of the building, i.e. The cladding should overlap the base, creating a run off for water. It is also recommended that the floor be at least 25mm above the surrounding ground level to avoid flooding.

TYPES OF BASE

- Durable plastic grid.
- Slabs laid on 50mm of sharp sand.
- Concrete 75mm laid on top of 75mm hard-core.
- Timber Base - Self constructed/Buy pre-made.



PLASTIC BASE

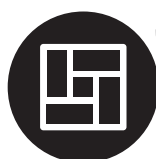

SLAB BASE



CONCRETE BASE



TIMBER BASE



BROKEN SLABS



BARE SOIL



LOOSE GRAVEL

**We recommend a Fastfit EcoBase for your building. It is durable, lightweight, flexible and easy to put in place. Please see [tigersheds.com](https://www.tigersheds.com) for details.*

ROOF COVERING OPTIONS

All Tiger buildings are designed to use **TigerFelt®** high grade poly-backed durable mineral roofing felt. If you have chosen a different roof covering option – such as EPDM rubberised roof covering or Shed Shingles, please see their separate roofing instructions available on their product pages at tigersheds.com.

MAINTENANCE

To validate your guarantee and ensure longevity of the product, it is ESSENTIAL that your building is treated with a suitable wood preserver or paint either BEFORE or AFTER assembly, both internally and externally. For the continued protection for unpainted areas of your garden building we recommend maintaining your timber treatment with **TigerSkin®** preserver. This solvent based wood treatment will penetrate deep into the wood giving years of protection against the weather and also enhance timber grain with a rich long lasting protection. A water repellent formula which is harmless to plants when dry, it is available in a wide range of colours to refresh the look and feel of your garden building. Discover more at tigersheds.com.

CAUTION:

All buildings should be erected by two competent adults.



CAUTION:

It is advisable to wear gloves during building installation.



The mark of responsible forestry

FSC® C125286



MADE IN THE UK SINCE 1913.

We have been making our high quality, great value sheds here in Britain for decades.

* **TigerSkin®** Water Based Treatment:

The unique formula of our **TigerSkin®** pre-treatment provides a reassuring layer of protection for your shed or summer house. Each panel is carefully dipped and dried to provide maximum coverage, and ensure that your building will have protection from the moment it arrives and is assembled. A water repellent formula which is harmless to plants, not only does it help to shield the timber, it also gives it a warm tone that looks great on your property. Once erected, your building should be treated regularly.

Whilst all products manufactured are made to the highest standards of Safety and in the case of childrens products independently tested to EN71 level, we cannot accept responsibility for your safety whilst erecting or using this product.

BEFORE YOU GET STARTED

TOOLS REQUIRED:

We recommend using the following tools (not supplied):



HAMMER



RUBBER Mallet



DRILL



LADDER



TAPE MEASURE



SHARP KNIFE



SPIRIT LEVEL



SCREWDRIVER +



WOOD SAW

FIXING KIT GUIDE:



Clout Nails (13mm Galvanised - QTY 175)



Black Drywall Screw (3.5x25mm - QTY 20)



Nail (40mm Galvanised - QTY 55)



Nail (65mm Bright - QTY 50)



Screws (4x50mm - QTY 50)



Screws (5x90mm - QTY 12)



Black Turnbutton (2 Inch - QTY 1)



Drop Bolt (QTY 1)

- Assembly is relatively straightforward if you follow these step by step instructions.
- We recommend getting everything aligned properly before screwing together and that **screw holes should be pre-drilled to avoid splitting the timber.** (Do not come pre-drilled).

IMPORTANT

- Before assembly please make sure you have a suitable base ready to erect your building on.
- This base **MUST** be firm and level to ensure that the building is assembled properly and lines up.
- Please carefully unpack the components in your delivery, and remove the timber supports that make up the delivery pallet.
- **CAUTION:** Parts may have moved during transportation. Be careful when unpacking supplied shed.
- **DO NOT** start your build until you have checked that all the parts of your building are present, correct and in a suitable condition.
- Pre-drilling screw holes is recommended to reduce the chances of the timber framing splitting.
- If you are organising a third party to install your building, it is best practice not to schedule this immediately on receipt of your order, to give you time to check your delivery.

BUILDING PACK CONTENTS:

For full details of what should be included please see the list that is supplied with the delivery. They are also available on request in pdf form from our helpful Customer Support team – please call 0113 2054189 for Customer Support or use the Items Delivered Query form at [tigersheds.com/contact](https://www.tigersheds.com/contact).

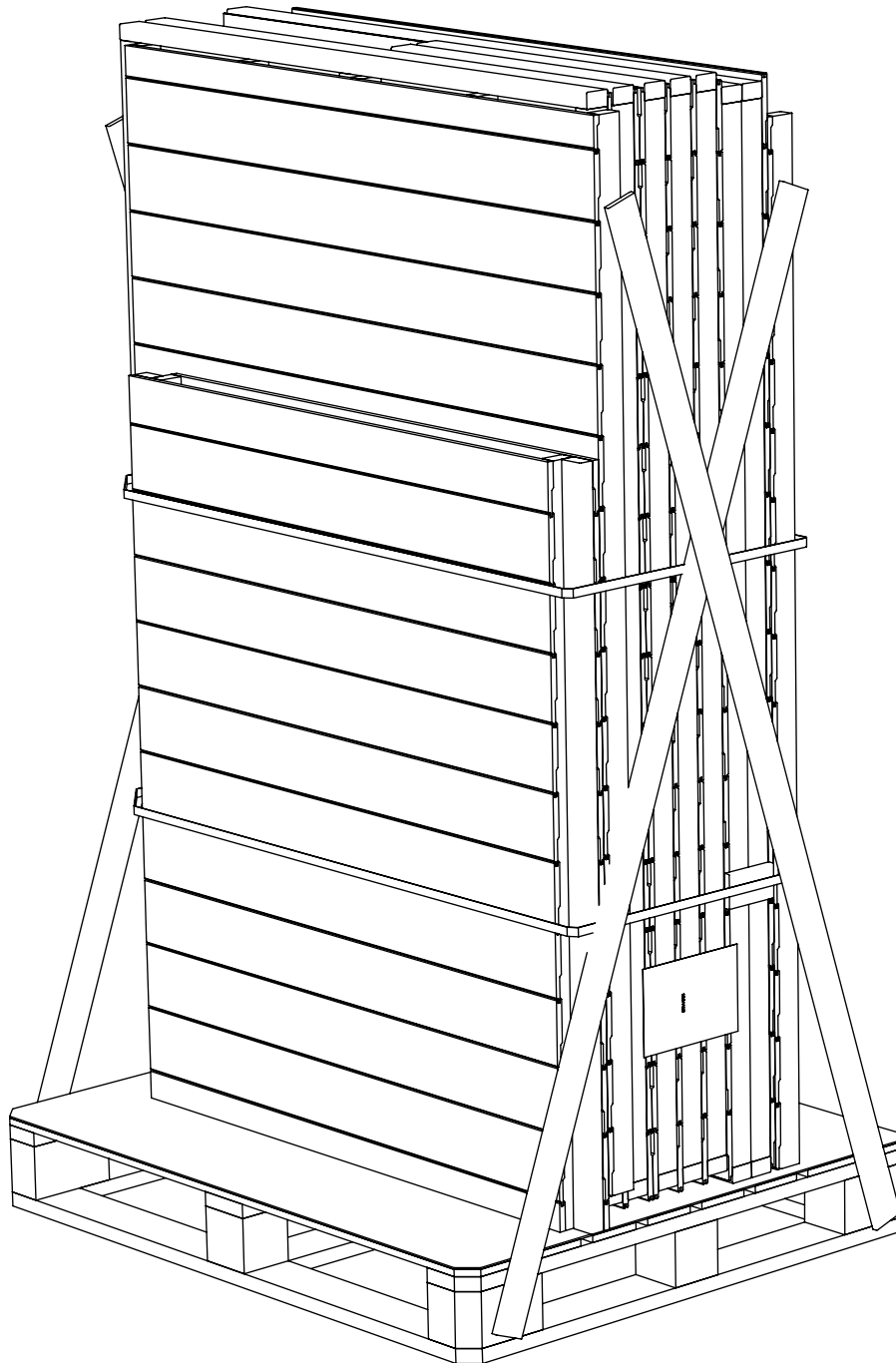

- From the outside working in, cut banding holding all components together and remove the panels. **Note: parts may have become loose or moved during transportation.**
- Large items like doors and windows are screwed into cross brace. Remove screws as you come to corresponding panel to reduce the risk of falling components.

TIGERFLEX® SHIPLAP APEX BIKE SHED ASSEMBLY GUIDE

Step 1: S90

FLOOR PANEL INSTALLATION

- Install Heavy Duty Bearers as shown
- Check your product floor size for the correct diagram (*opposite page*).
Please ensure floor panels are butted up tightly with no gaps
- Secure bearers to floor panel using 2x 90mm **(S90)** screws per bearer.
NOTE - Make sure fixings go through floor joists.

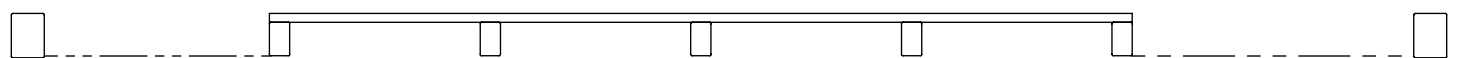
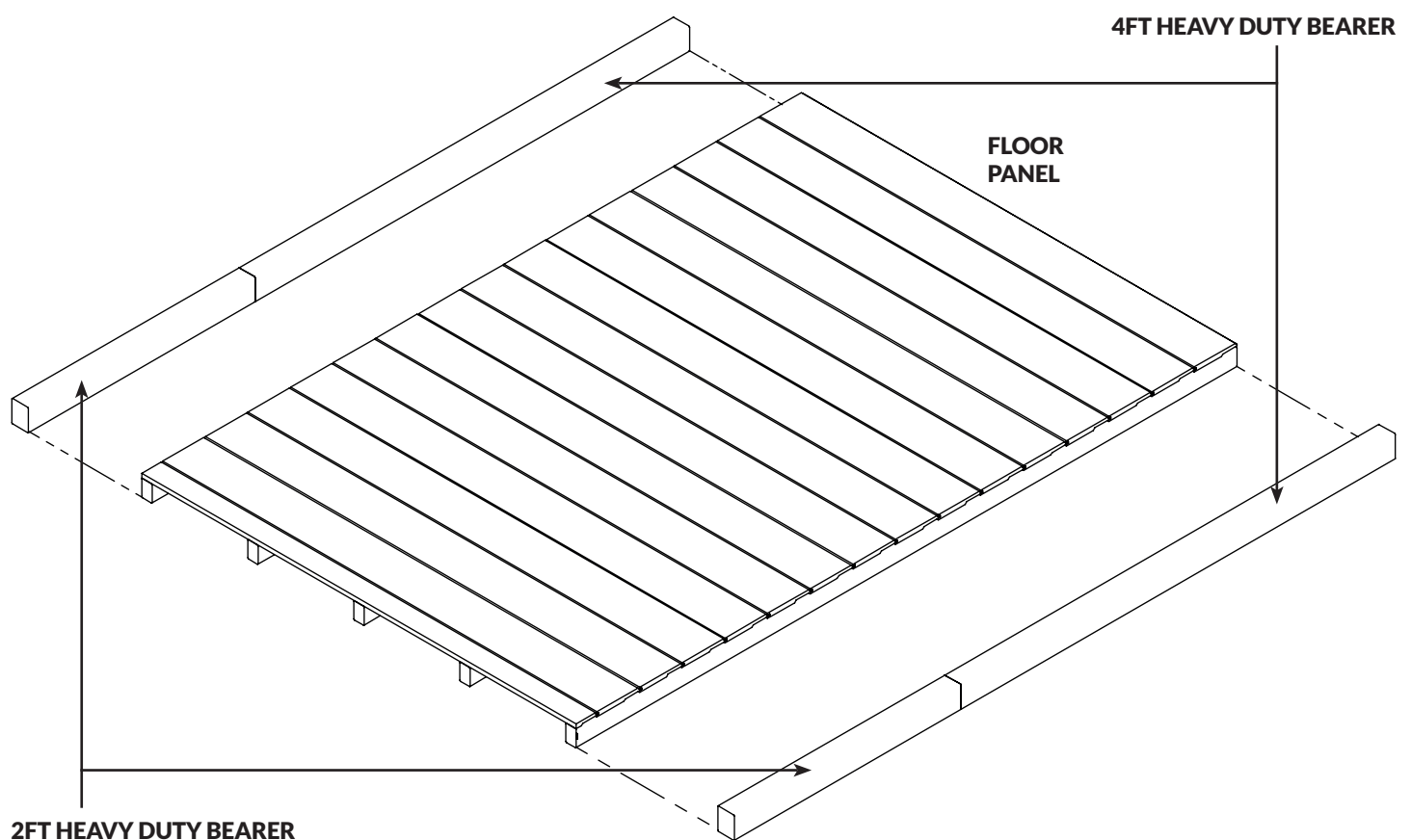

SINGLE FLOOR
6x3*, 6x4*

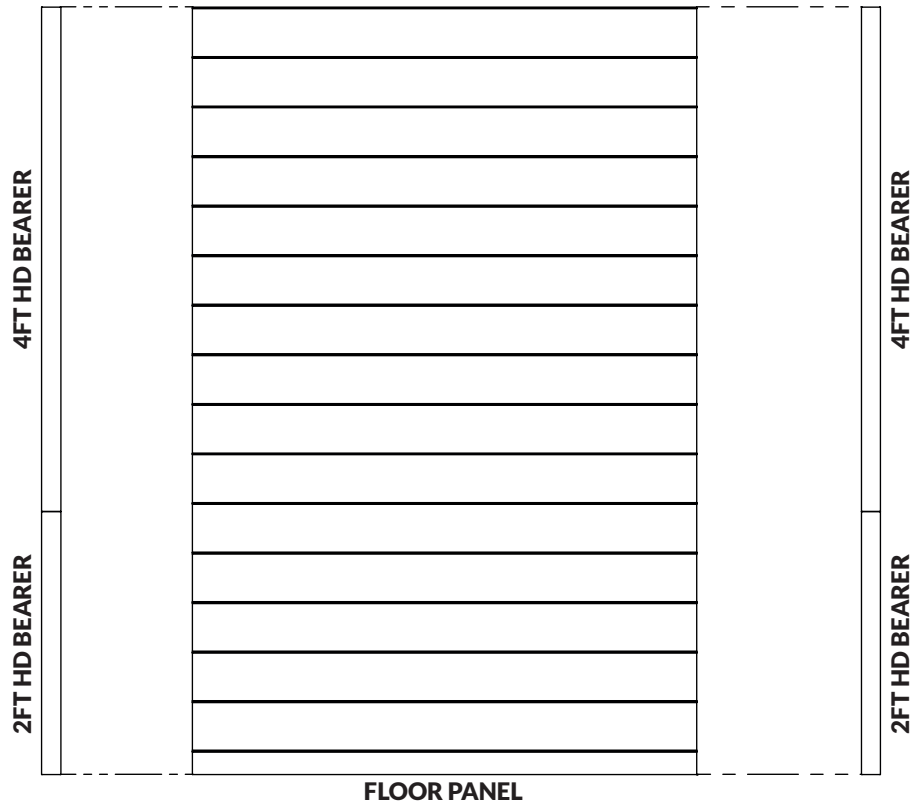

MULTI FLOOR
6x5*, 6x6*

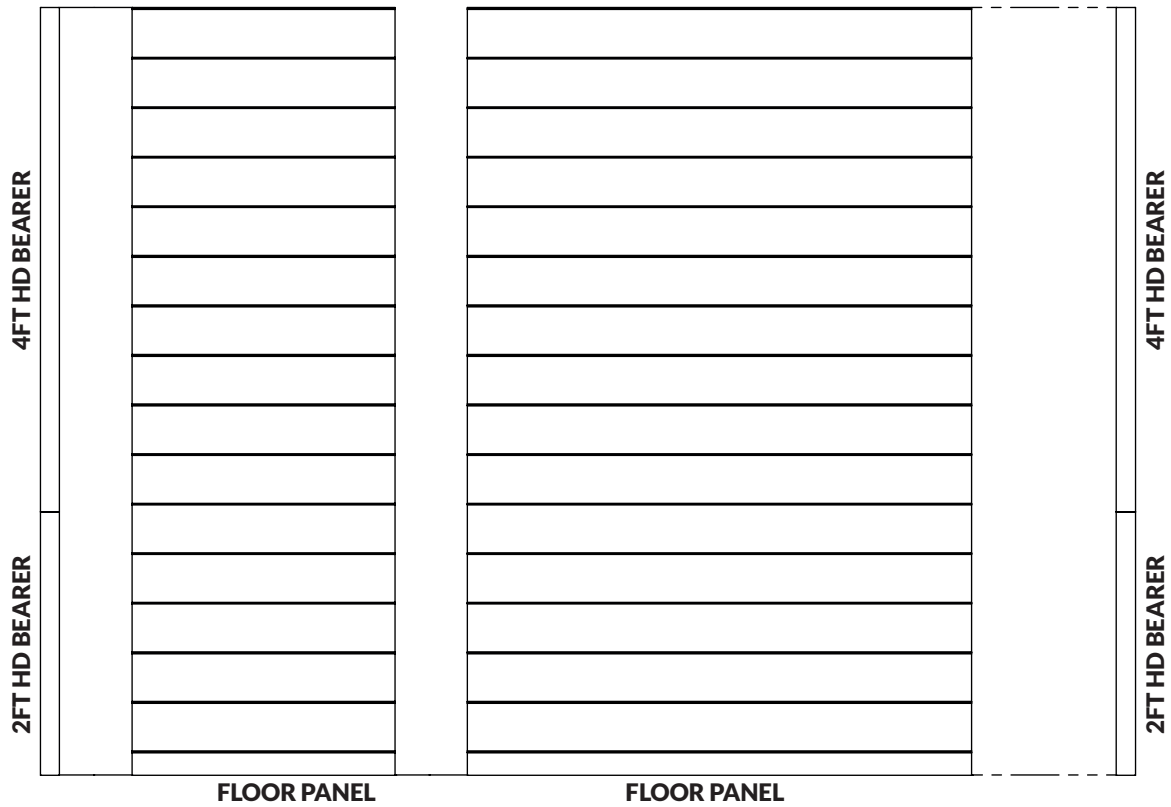

TIGERFLEX® SHIPLAP APEX BIKE SHED ASSEMBLY GUIDE

Step 2: S50 N65

SIDE PANEL INSTALLATION

Make sure transport blocks have been removed. **(Detail A)**

NOTE - Hammer off sideways. Do not prise off.

- Secure blank back & blank side panel to each other in corners using 3x 50mm **(S50)** screws per joint. **(Detail B)**
- Secure blank panels to the floor using 65mm **(N65)** nails **(Detail C & D)**
NOTE - Make sure fixings go through floor joists or into heavy duty timber bearers.
- Secure blank panels to each other in using 3x 50mm **(S50)** screws per joint.
Only applies to side panels butting against each other. **(Detail E)**

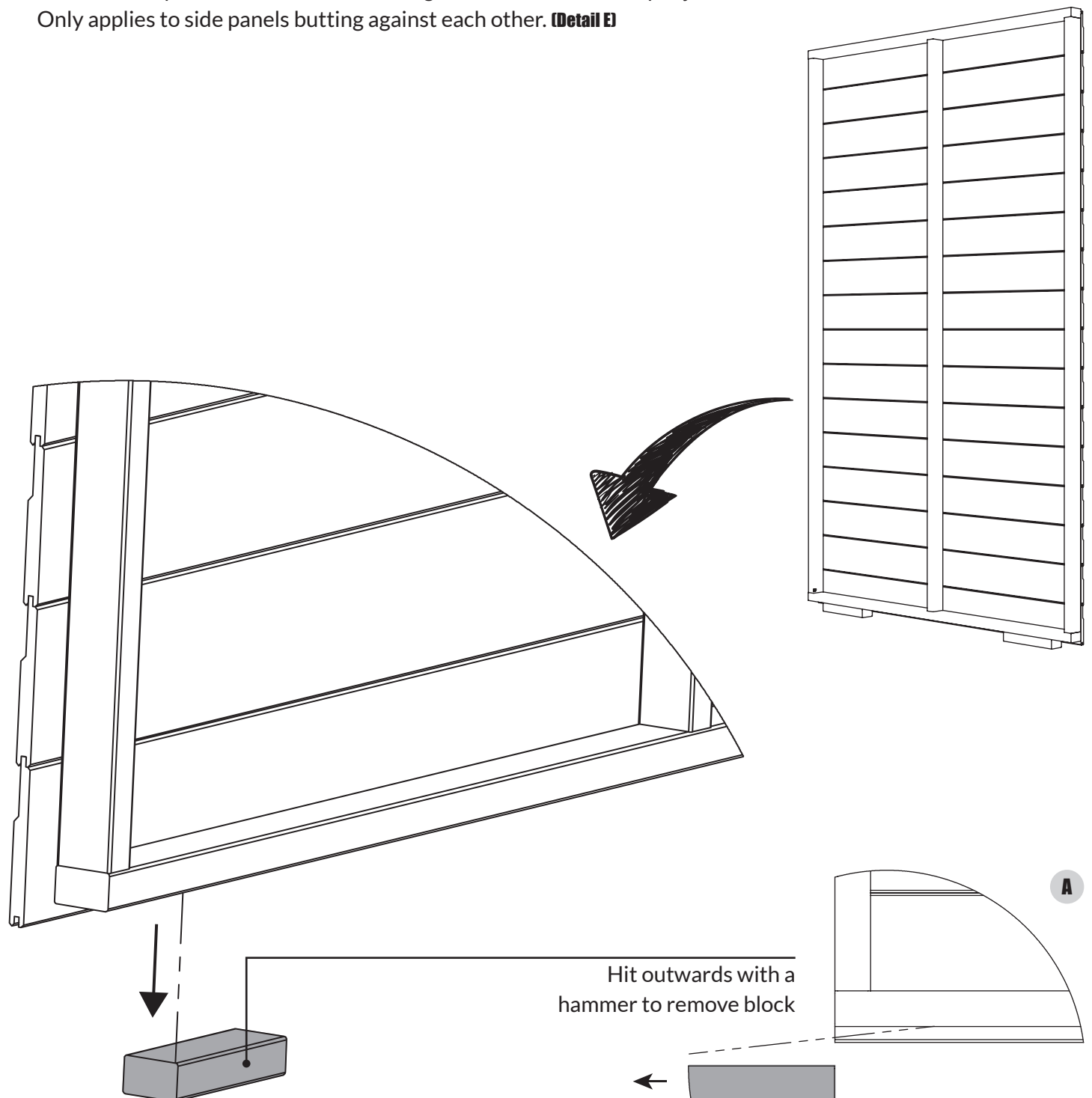

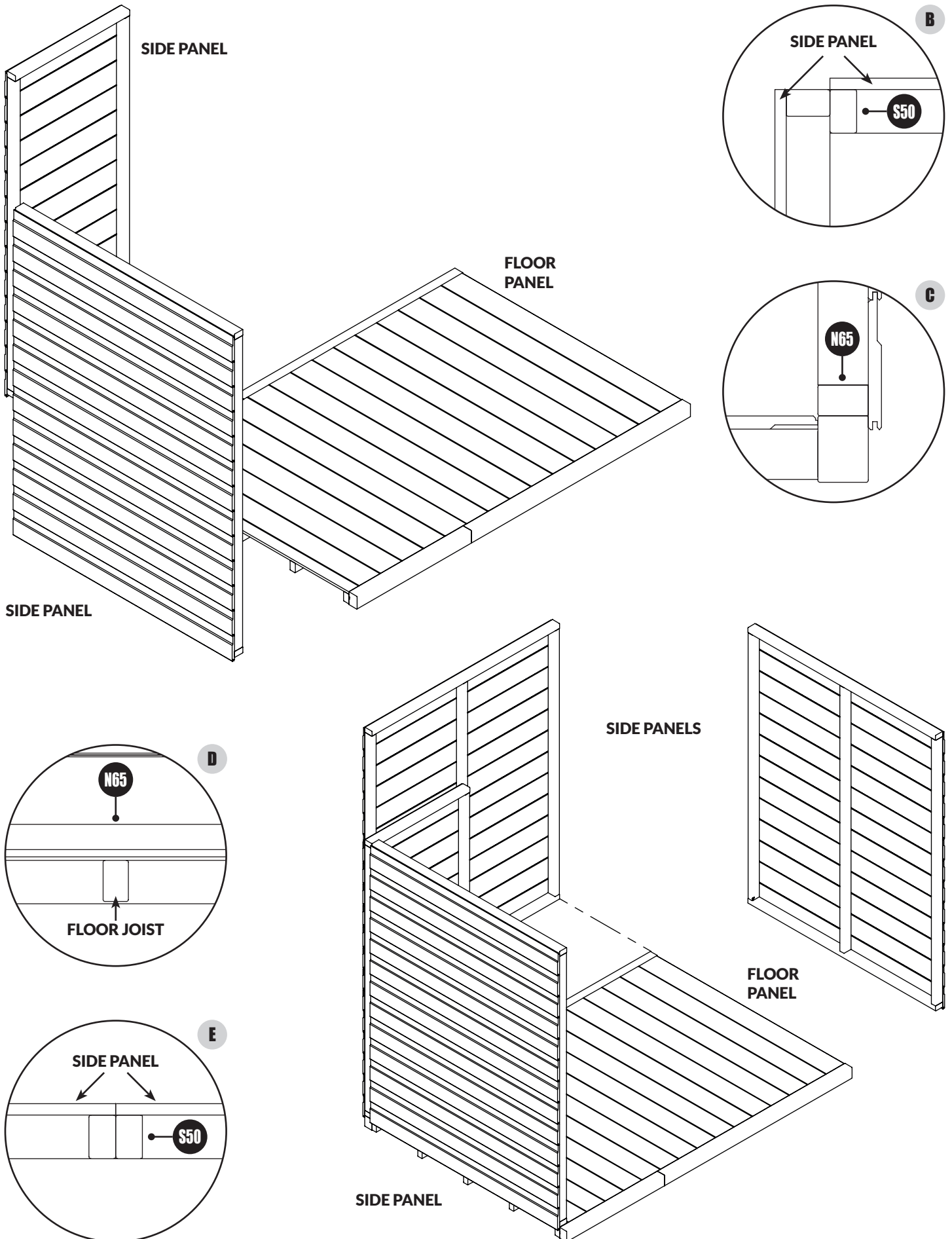

TIGERFLEX® SHIPLAP APEX BIKE SHED ASSEMBLY GUIDE

Step 3:

DOOR SIDE PANEL INSTALLATION

- Assemble door side panel as shown. (Before affixing to the shed).
- Screw door header to the left and right hand sides as shown using 50mm **(S50)** screws. **(Detail F)**
NOTE - Predrill holes to reduce chance of wood splitting
- Screw door base to the left and right hand sides as shown using 50mm **(S50)** screws. **(Detail G)**
- Check frame is square by measuring across corners.

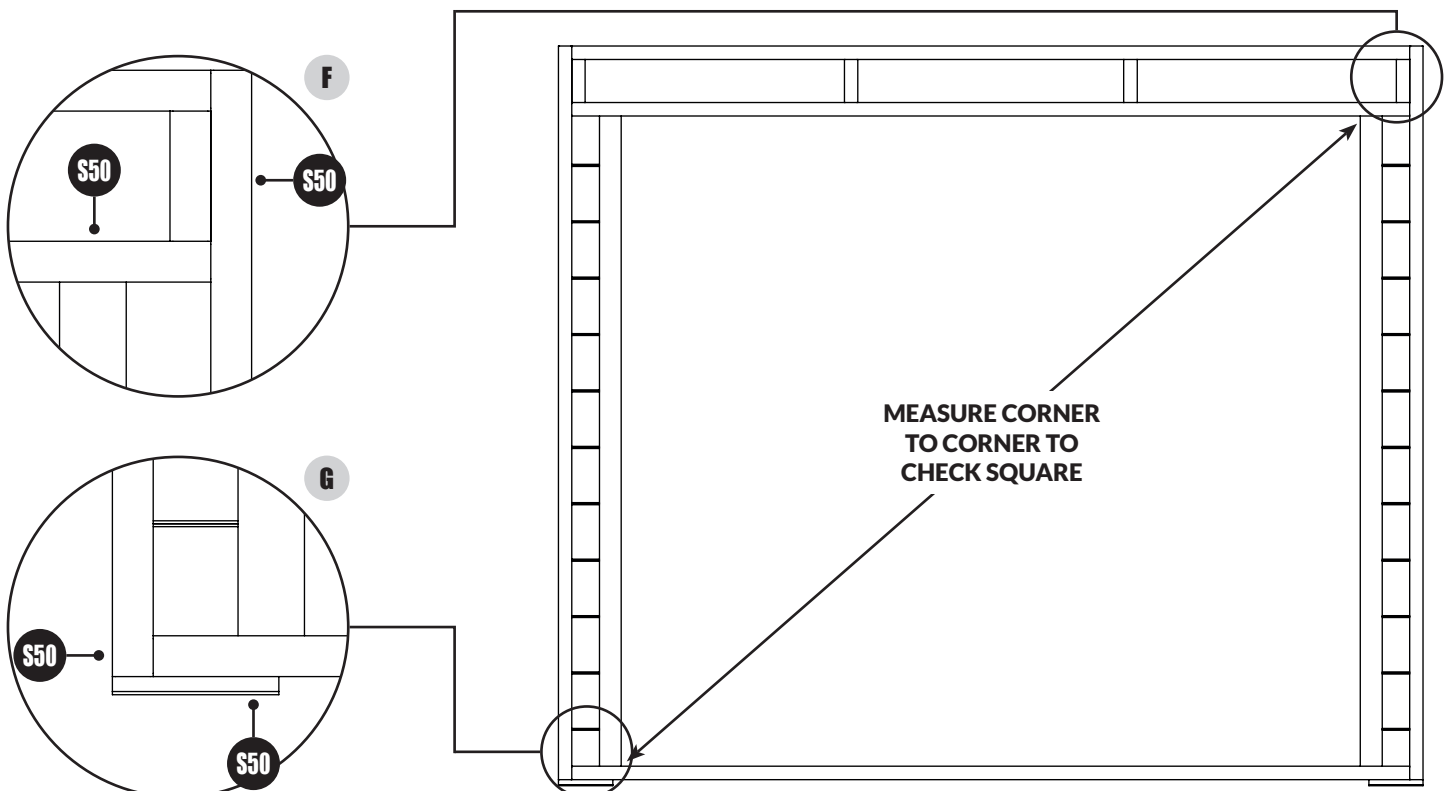
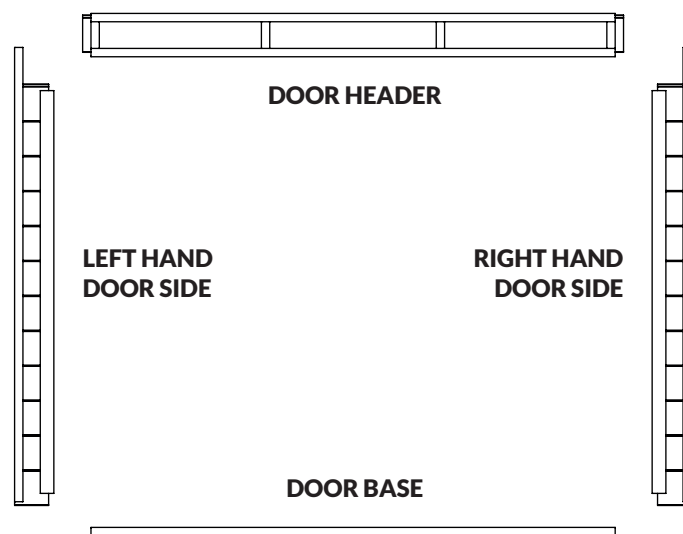

Step 4:

DOOR INSTALLATION

- Lay assembled door side panel on a flat surface
- Place doors into opening.
- Leave approx. 4mm gap at side between door and side panel. **(Detail H)**
- Leave approx. 6mm gap at top between door and side panel. **(Detail I)**
- Secure in place using 3x 25mm **(BS25)** screws per hinge - 6 hinges in total. **(Detail H)**
- Mark position of Drop Bolt **(DB)** on the door header and door base and drill hole. **(Detail I & J)**
- Secure Turn Button **(2TBB)** using 1x **(BS25)** screw **(Detail K)**

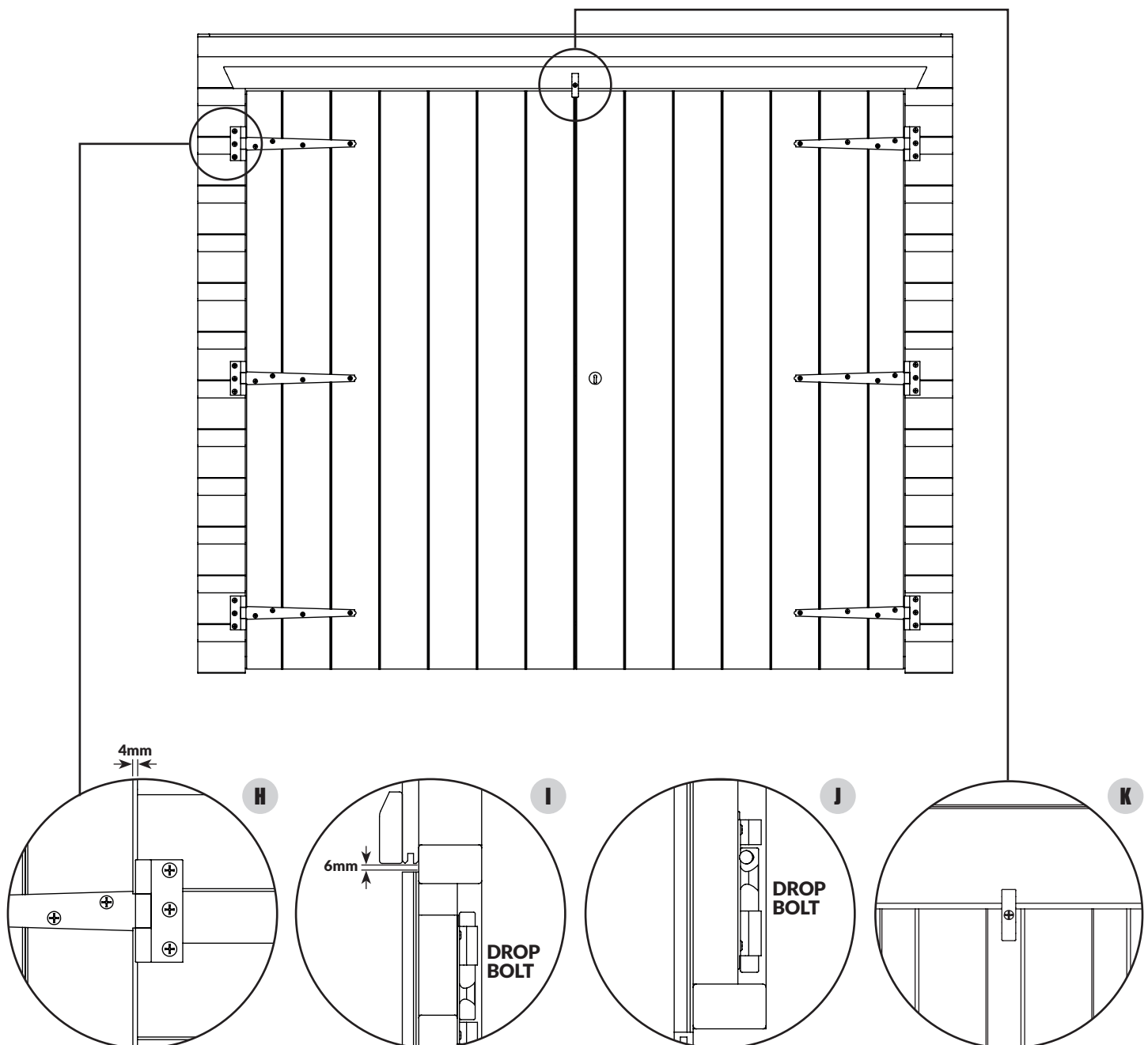

TIGERFLEX® SHIPLAP APEX BIKE SHED ASSEMBLY GUIDE

Step 5:

COMPLETED DOOR SIDE PANEL INSTALLATION

- Secure completed door side panel to existing built structure as shown..
- Secure in corners using 3x 50mm **(S50)** screws provided per joint. **(Detail L)**
- Secure to floor using 4x 65mm **(N65)** nails. **(Detail M)**

NOTE - Make sure fixings go through floor joists or into heavy duty timber bearers.

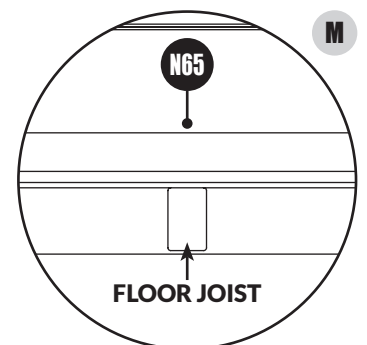
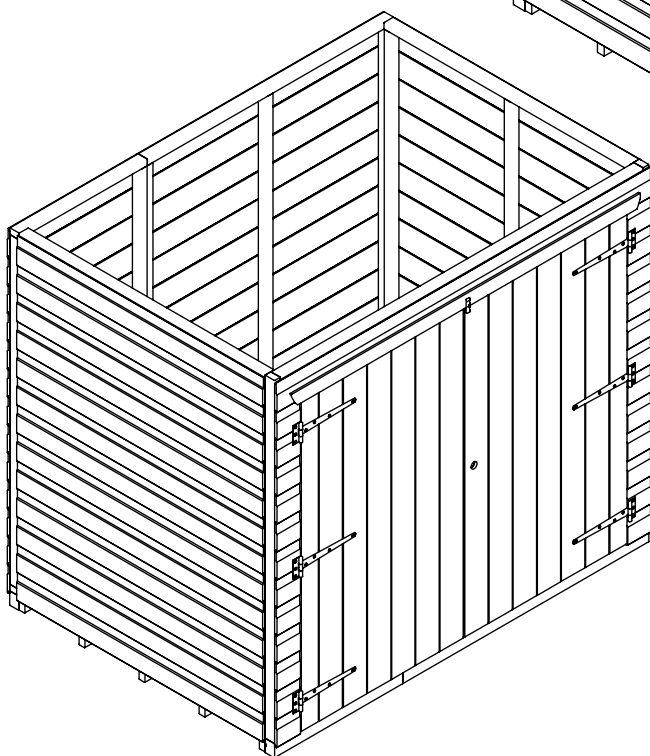
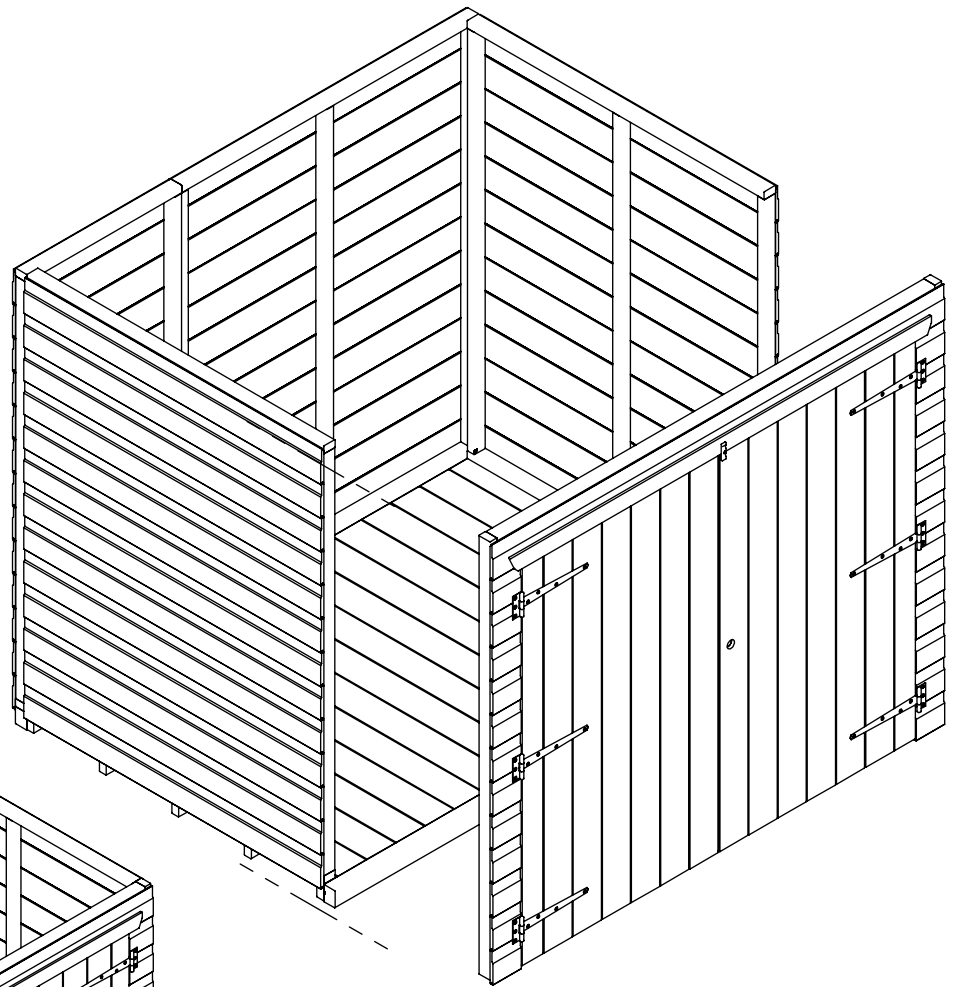
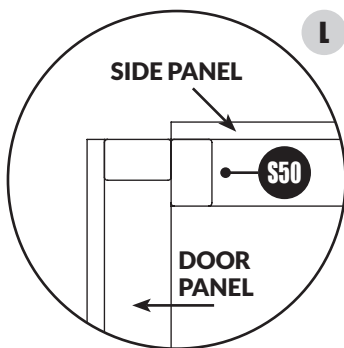

Step 6: S50

APEX GABLE TOP INSTALLATION

- Fix Apex Gable Tops to the existing built structure.
- The bottom of the gable top will slot into the top of the cladding on the panel below. Please ensure the gable top is positioned centrally above the side panels before screwing in place.
- Secure through top of side panels using 4x 50mm **(S50)** screws per gable top. **(Detail N)**

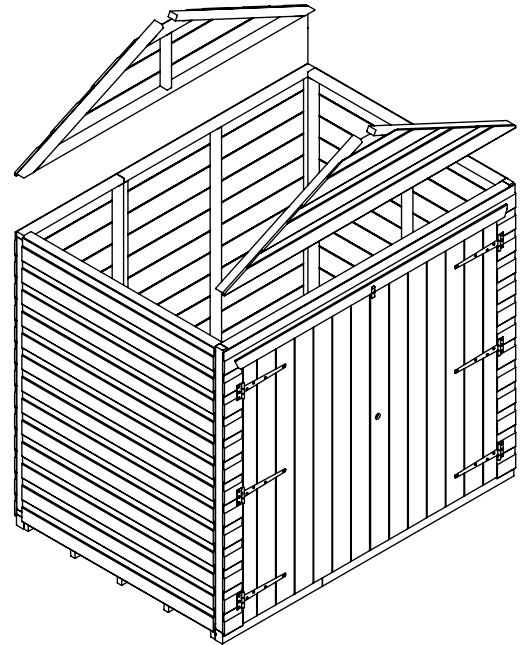
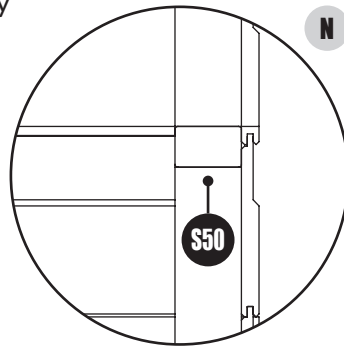

Step 7: S50

APEX ROOF PANEL INSTALLATION

- Attach roof panels as shown. Hook roof panel purlin into Apex Gable Top. **(Detail O)**
- Before screwing roof panels into place, check there is an even overhang at both ends and that the panels are sitting square before securing along the apex/ridge.
- Secure together along the Apex Ridge using 50mm **(S50)** screws.
- Secure to Apex Gable Tops using 2x 50mm **(S50)** screws per roof panel. **(Detail P)**

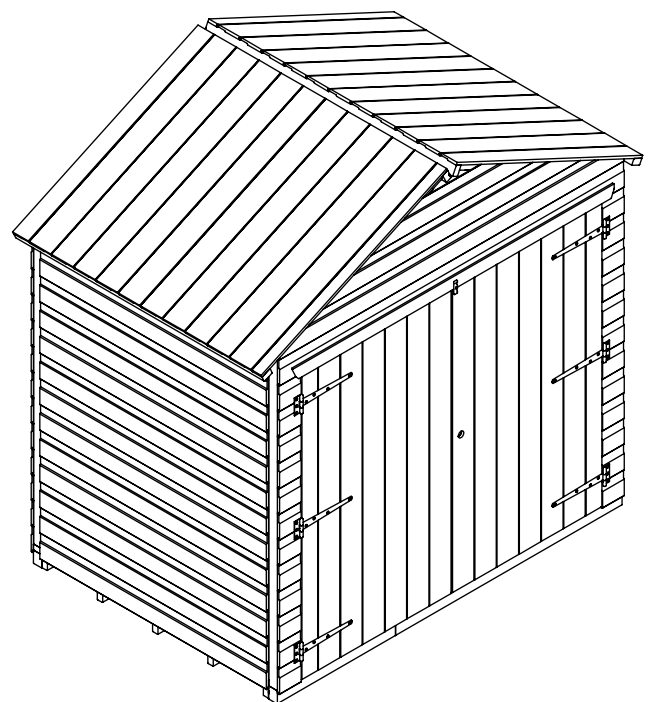
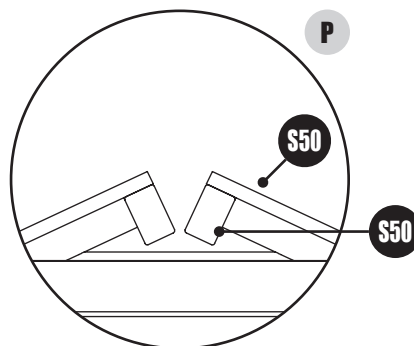
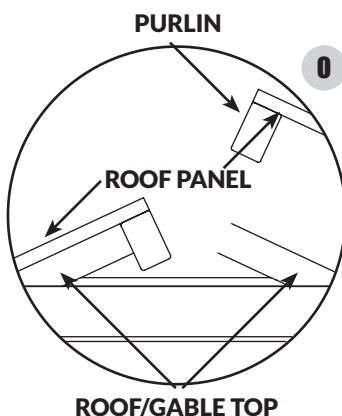

TIGERFLEX® SHIPLAP APEX BIKE SHED ASSEMBLY GUIDE

Step 8:

FELT INSTALLATION

- Roll out felt along lower part of roof, leaving sufficient overhang to fold down onto roof purlin, approx 75mm/3". **Do not fold underneath roof.**
- Use clout (**CN13**) nails to tack top of felt into the roof panel.
- Repeat for the other side. Fold the overhang at gable ends under the roof panel and tack in place.
- Ridge piece should overlap the lower strips and tack into place (if supplied).

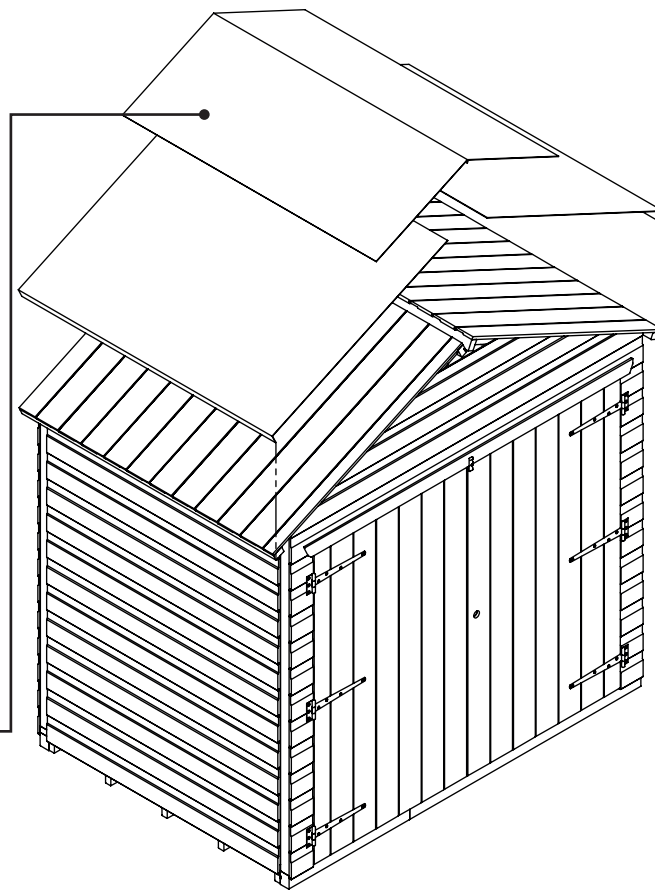

Step 9:

BARGE BOARD & FINIAL INSTALLATION

- Fit Barge Boards to the roof, trapping overhanging end of the felt in between to create a weatherproof seal.
- Secure together using 2x 40mm (**N40**) nails per Barge Board.
- Fit Finials at the apex point of the Barge Boards. Secure together using 2x 40mm (**N40**) nails per finial.

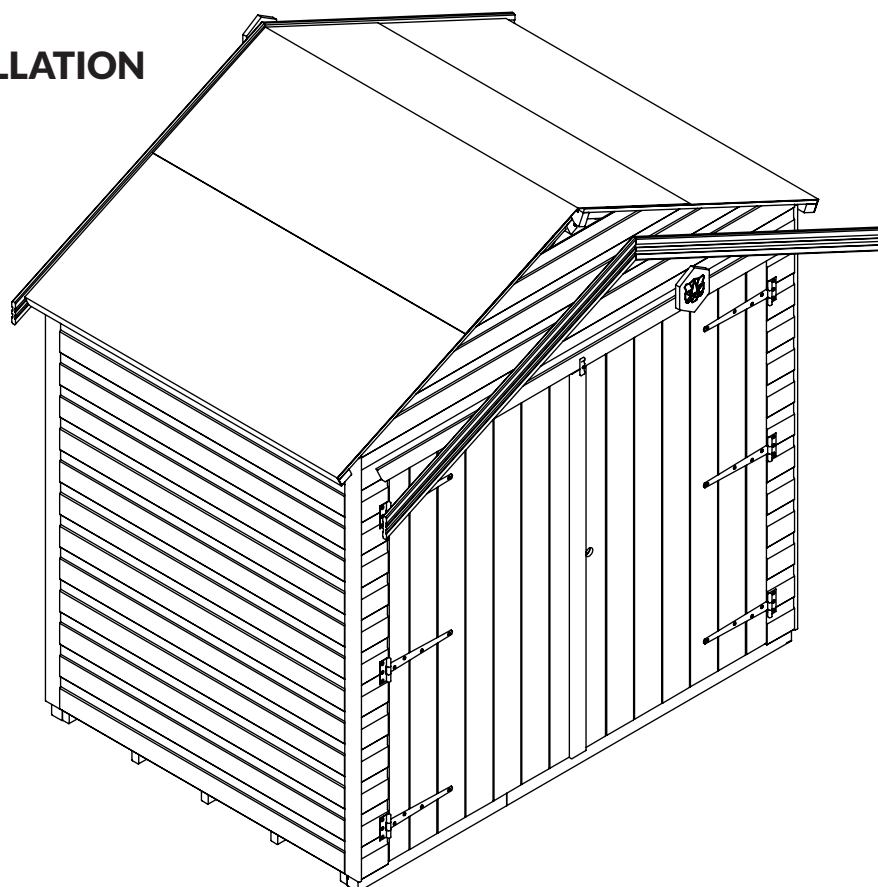

Step 10:

COVER LAT & CORNER STRIP INSTALLATION

- Fit Corner Strips in the corners of the shed, these are plain profiled pieces.
- Secure to the shed using 3x 40mm (N40) nails per Corner Strip. (Detail Q)
- Fit Cover Lats over joints where 2 panels butt against each other. These are grooved both sides.
- Secure to the shed using 3x 40mm (N40) nails per Cover Lat. (Detail R)
- Corner Strips and Cover Lats will need trimmed to fit.

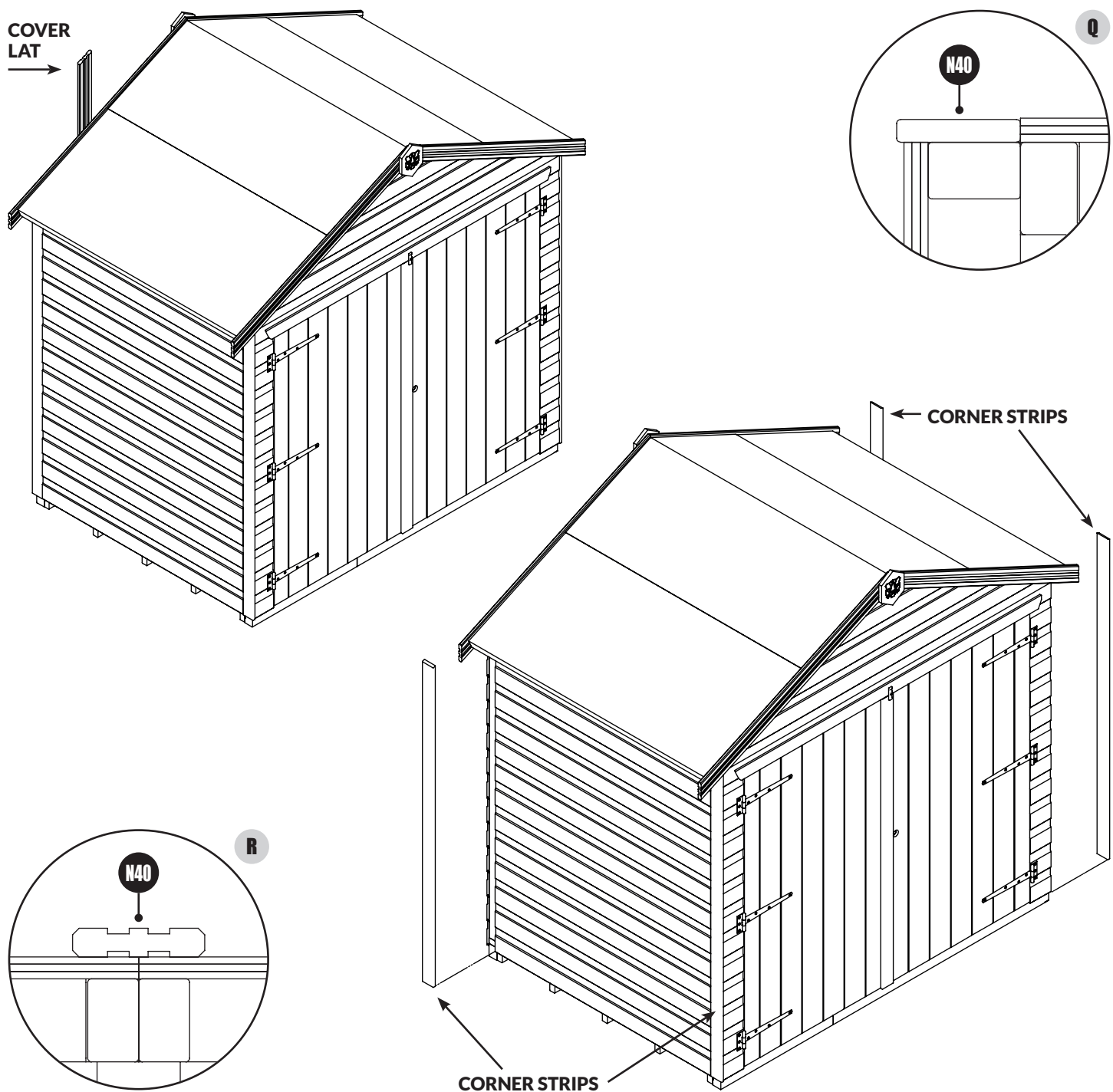



Display Agent

Woodlands DIY Store
Station Yard,
Horsforth,
Leeds,
LS18 5NZ

Telephone: 0113 205 4189
Website: tigersheds.com
Email: customersupport@tigersheds.com

